

A
1 FRONT ELEV. SCALE: 1" = 12"

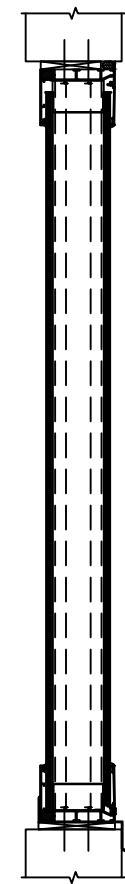

B
1 SECTION SCALE: 1" = 12"

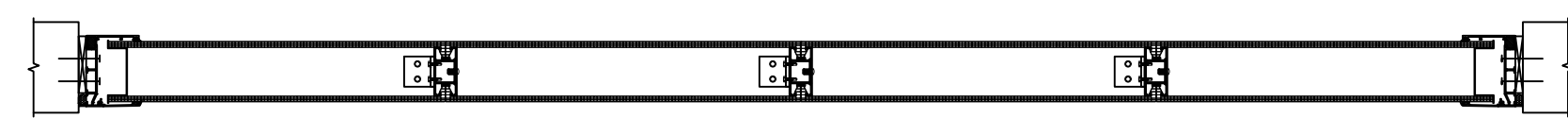

C
1 CROSS SECTION SCALE: 1" = 12"

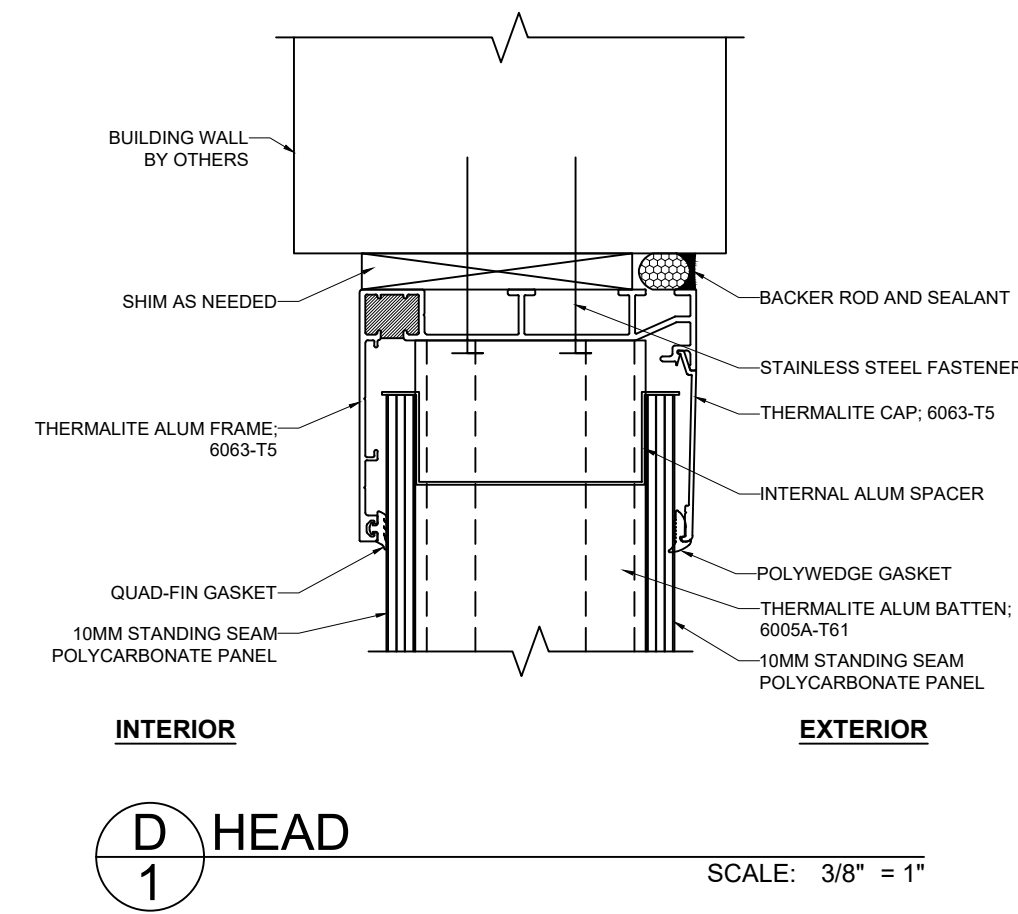

D
1 HEAD SCALE: 3/8" = 1"

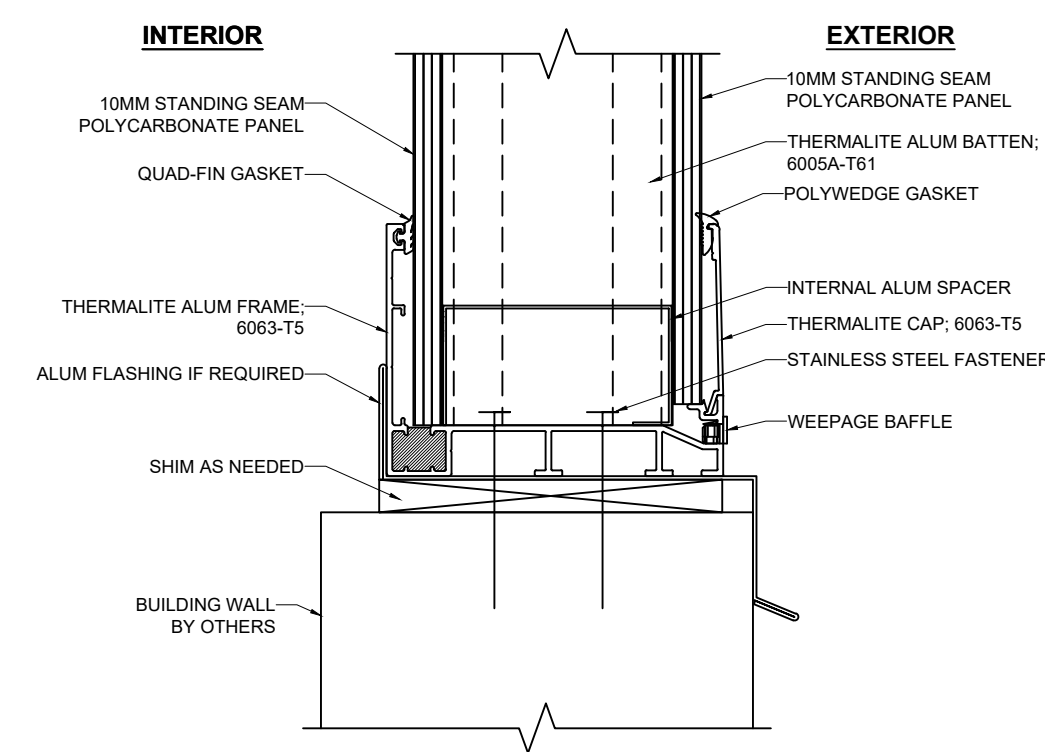

E
1 BASE SCALE: 3/8" = 1"

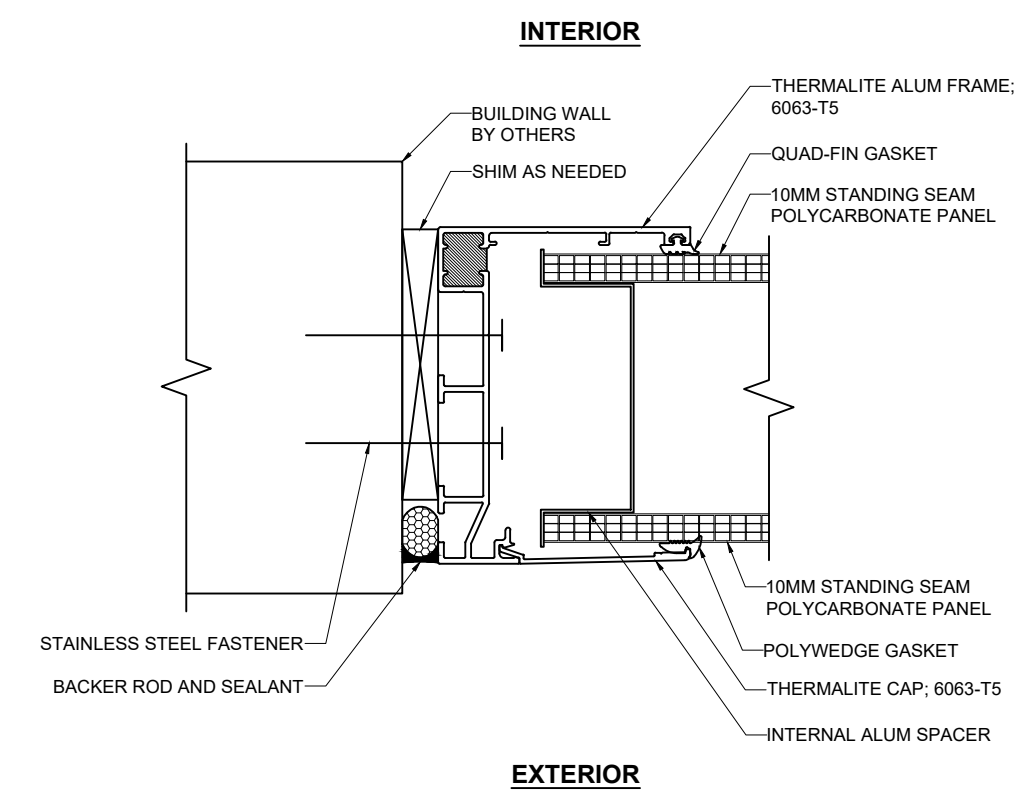

F
1 JAMB SCALE: 3/8" = 1"

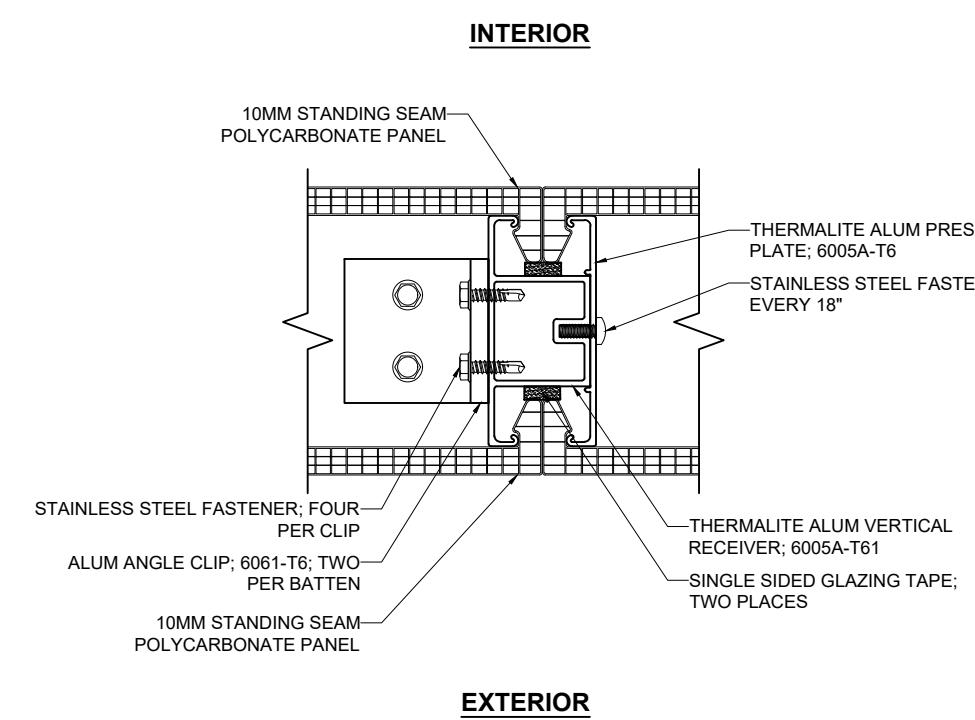

G
1 TYP. VERTICAL RECEIVER SCALE: 3/8" = 1"

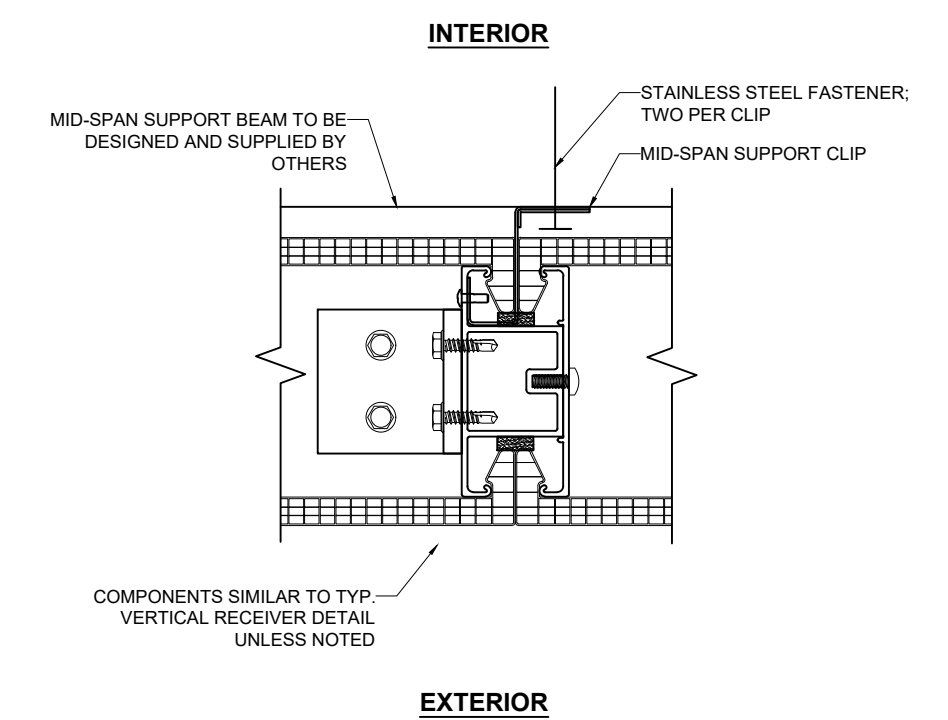

H
1 MID-SPAN SUPPORT FOR TALL SPANS SCALE: 3/8" = 1"

Glazing Type: Thermalite Plus

0.3937" 0.3937"

10mm Polycarbonate
Co-extruded UV Protection
Co-extruded UV Protection

10mm Polycarbonate
Co-extruded UV Protection
Co-extruded UV Protection

Exterior Interior

1 2 3 4

4"

Thermalite Plus Translucent Wall Panel